



**Öhlins Front Fork for
Motocross and Enduro**

Owner's Manual



Safety Precautions

Note!

The front fork is a very important part of the vehicle and will therefore affect the stability.

 Read and make sure that you understand the information in this manual and the mounting instructions before you use this product. If you have any questions regarding installation or maintenance please contact your Öhlins dealer.

 Öhlins Racing AB can not be held responsible for any damage to the front fork, vehicle, other property or injury to persons, if the instructions for installing and maintenance are not followed exactly.

Warning!

This product was developed and designed exclusively for a specific vehicle model and shall only be installed on the intended vehicle model in its original condition as delivered from the vehicle manufacturer.

 This product contains pressurized nitrogen gas (N₂). Do not open, service or modify this product without proper education (authorized Öhlins dealer/distributor) and proper tools.

 After installing this product, take a test ride at low speed to make sure that your vehicle has maintained its stability.

 If the suspension makes an abnormal noise, or the function is irregular, or if you notice any leakage from the product, please stop the vehicle immediately and return the product to an Öhlins Service Centre.

Note!

When working on this product, always consult this Owners Manual.

 This Manual shall be considered a part of the product and shall therefore accompany the product throughout its life cycle.

Safety Symbols

In this manual, mounting instructions and other technical documents, important information concerning safety is distinguished by the following symbols:



The Safety Alert Symbol means: Warning! Your safety is involved.

Warning!

The Warning Symbol means: Failure to follow warning instructions can result in severe or fatal injury to anyone working with, inspecting or using the front fork, or to bystanders.

Caution!

The Caution Symbol means: Special precautions must be taken to avoid damage to the front fork.

Note!

The Note Symbol indicates information that is important regarding procedures.

	Page
Safety Precautions	2
Recommended Tools	3
How to Install	4
Replace Spring	6
Set-up	8
Measure Spring Preload	9
Adjustments	10
Diagram; Oil Volume - Force	10
Spring Guide	11
Inspection and Maintenance	12

Recommended Tools

Öhlins Front fork Installation

See your Vehicle Owner's Manual for proper instructions for OEM front fork removal and installation.

Öhlins Front Fork Service Tools

- Fork Cap Tool octagon 50mm
- Socket 12mm for Öhlins shaft end
- Pliers (for security snapping)
- Tool 01890-01 Plug
- Bushing removal tool 01702-04 (with top part 01702-13)
- Bushing / Seal mounting tool 01799-04

How to Install

⚠ Warning!

It is advisable to have an Öhlins dealer install the front fork.

When installing, consult your Vehicle Service Manual.

1

Put the motorcycle on a workstand so that the front wheel is off the ground.

⚠ Warning!

Make sure the vehicle is securely supported so that it will not tip.

2

Remove the front wheel, plastic fork leg protectors and brake caliper.

👁 Note!

Note the fork height position (see step 3).

3

Measure the distance from the top of the upper triple clamp to the centre of the front wheel axle, according to figure, make a note.

4

Loosen the upper triple clamp by loosening the screws.

5

Loosen the lower triple clamp by loosening the screws.

6

Remove the front fork legs from the motorcycle.

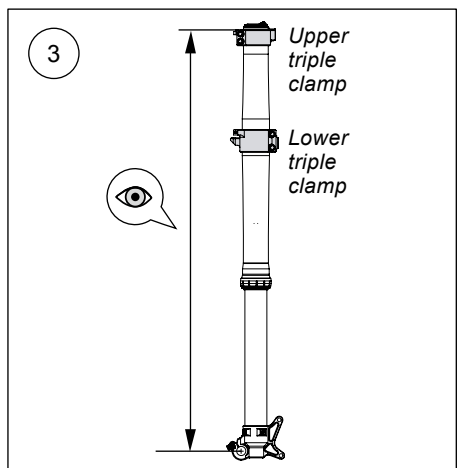
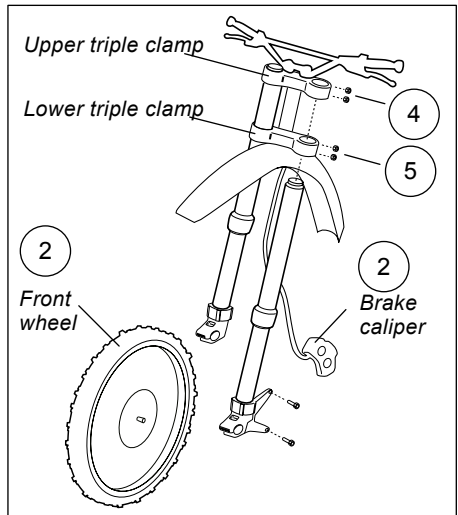
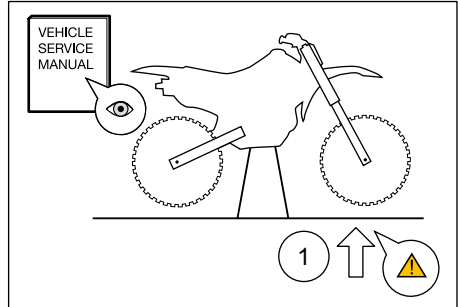

How to Install

Note!

On some models you will need to install Öhlins triple clamps (provided in the kit). See your vehicle service manual for instructions how to remove the upper and lower triple clamp. OEM steering stem and steering bearing need to be removed from OEM lower triple clamp and installed to the Öhlins triple clamp.

Caution!

It is advisable to have an Öhlins dealer remove and install the steering stem.

7

Consult your vehicle service manual for instructions on how to install lower and upper triple clamp and how to achieve the correct steering bearing free play.

8

Install the front fork legs into the triple clamps. Use, to start with, the same height position as measured in step 3. Rotate the fork legs in the triple clamps to achieve good access to the adjusters in the fork leg top cap. We recommend turning the adjuster access point towards the rear of the motorcycle ("Ö"-logo readable from riding position).

9

Install the upper fork leg sticker rotated to your liking and install lower plastic fork leg protectors. Tighten top and bottom triple clamp bolts;

Tightening torque

Top triple clamp M8	20Nm
Bottom triple clamp M8	15Nm
Fork protectors M6	7Nm

10

Reinstall the brake caliper and the front wheel. Tighten brake caliper bolts. Tighten front wheel nut and left side fork bottom bolts. Make sure front fork legs are parallel before tightening the right side fork bottom bolts.

Tightening torque

Brake caliper M8	25Nm
Front wheel axle	50Nm
Fork bottom M8	15Nm

Note!

It is very important that the triple clamps are tightened to the correct torque.

11

Make sure that all removed parts are re-installed according to instructions in your vehicle service manual.

Replace Spring

👁 Note!

We advise you to loosen (not remove) the top cap from the outer tube when the fork leg is still fixed by the lower triple clamp.

1

To remove the fork, follow steps 1-6 in chapter *How to Install*.

2

Unscrew the top cap from the outer tube.

3

Remove the security snapping at the bottom of the fork with a pair of pliers. Loosen the bottom end of the cartridge kit by turning it clockwise.

4

Install the tool 01890-01 (oil plug) by pushing it into the fork bottom. The plug will keep the oil in the fork while changing the spring.

5

Remove the cartridge kit from the fork leg and change the spring. Note the plastic preload washer(s).

👁 Note!

The preload washers must be placed below the spring, at the bottom end of the fork leg.

6

Install the cartridge kit into the fork leg and push out the oil plug tool 01890-01.

7

Tighten the shaft end (counter clockwise) into the fork bottom. Tightening torque 18 Nm.

8

Install the security snapping.

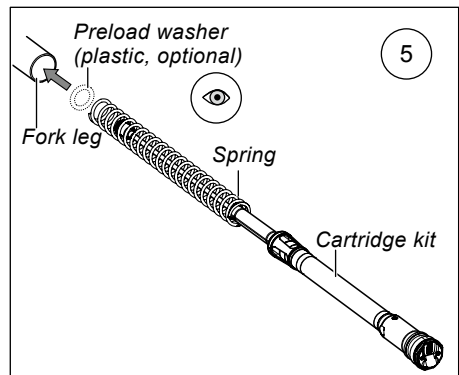
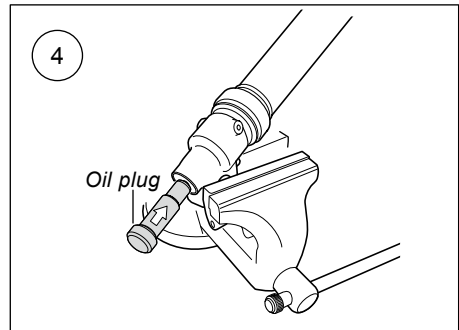
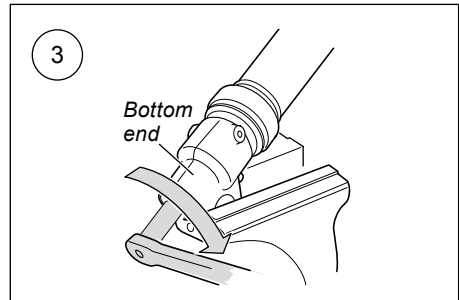
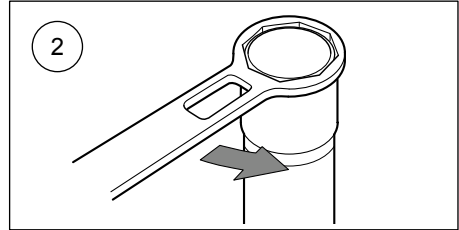

Replace Spring

Note!

When removing spring and cartridge kit there will be a loss of front fork fluid. Therefore, we recommend adding 15 ml Öhlins Front Fork fluid into each fork leg.

9

Tighten the Öhlins fork top cap gently. Use a 50 mm octagon Fork Cap Tool.
Tightening torque maximum 10 Nm.

10

Install the front fork and all other removed parts according to step 8-10 in chapter "How to install".

Note!

It is very important that the triple clamps are tightened to the correct torque.

Note!

Make sure that all removed parts are reinstalled as they were before the installation of the Öhlins Kit.

Set-up

⚠ Warning!

Before riding, always ensure that the basic settings made by Öhlins are intact. Take notes, adjust in small steps and make only one adjustment at a time.

Step 1

Check Sag and Ride Height

👁 Note!

The following procedure should be performed on a flat surface.

1. Put the motorcycle on a workstand so that both wheels are off the ground and the suspension is unloaded.
2. Mark, for example with a piece of tape, a point immediately above the rear wheel axle.
3. Measure the distance from the marked point to a fixed point, for example the wheel axle. (See figure below: R1)
4. Measure the distance from the bottom of the upper triple clamp to a fixed point, for example the front wheel axle. (F1)
5. Put the motorcycle on the ground so that the front and the rear suspensions are slightly compressed. Repeat the measuring procedures. (R2 and F2)
6. Sit on the motorcycle in normal riding position, properly outfitted in your riding gear. Repeat the measuring procedures. (R3 and F3)

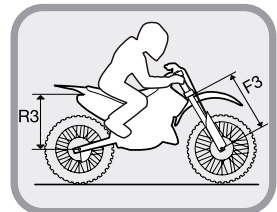
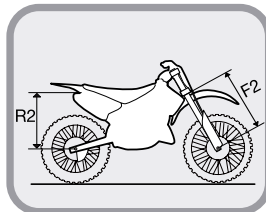
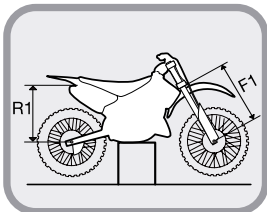

Recommended Measures

If no other recommendations are given in the Vehicle Manual follow the measures below:

Free sag (R1-R2)

Rear 30 - 45 mm

Ride height (R1-R3), (F1-F3)

Rear 100 - 115 mm

Front 40 - 50 mm

Step 2

Adjust spring preload

1. If your measurements differ significantly from the recommendations in the table above, adjust the spring preload. (See section Spring Preload in this manual).
2. If the ride height still differs from the recommendations, you may need to change spring. Contact an Öhlins dealer for advise.

⚠ Warning!

Incorrect spring rate may produce a fork angle that is too steep or too flat. This in turn will give a tendency for over- or understeering, which could seriously affect the handling characteristics of the motorcycle.

Measure Spring Preload

Five Steps to measure and adjust spring preload;

1. Measure A. Fork outer tube should be slid down to stop and cartridge left at free length (internal gas pressure extends cartridge).
2. Measure B.
3. Measure C.
4. Calculate preload: $\text{Preload} = B - A - C$
5. Adjust preload according to the desired value according to set-up data, by adding/removing preload washers below the spring.

Fork springs may differ in length. Therefore we recommend you to check the preload on each fork leg and, if necessary, install preload washers to get the correct value.

Preload less than -0 mm will make the fork springs loose when the front wheel is off the ground, which increases wear inside the fork.

Caution!

Preload washers must be placed below the spring, otherwise they will restrict oil flow and the Front Fork function.

For recommended Spring Preload, see Supplementary Mounting Instruction.

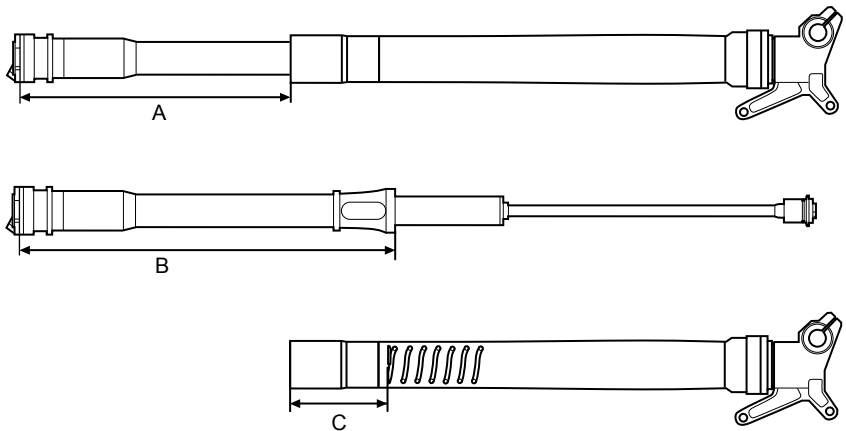

Adjustments

Compression damping adjuster

The compression adjuster is located at the top of the fork leg. Adjust by turning the screw with a 3 mm allen key.

Rebound damping adjuster

The rebound adjuster is located at the bottom of the fork leg. Adjust by turning the screw with a 3 mm allen key.

To Reset

The adjusters have a normal right hand thread. Turn the damping adjusters gently clockwise to fully closed (pos. zero [0]). To open, turn counter clockwise, and count the clicks until you reach the recommended number. For recommended clicks see Set-up data in Supplementary Mounting Instruction.

Caution!

Do not use force when checking zero position, delicate sealing surfaces can be damaged.

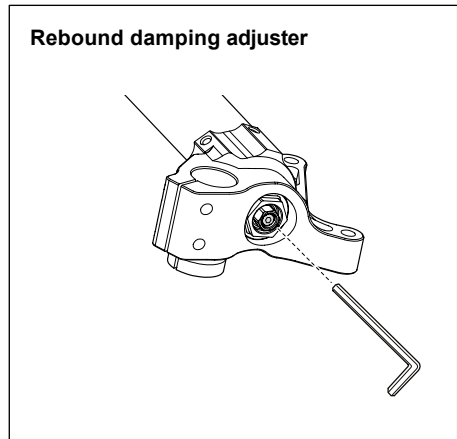
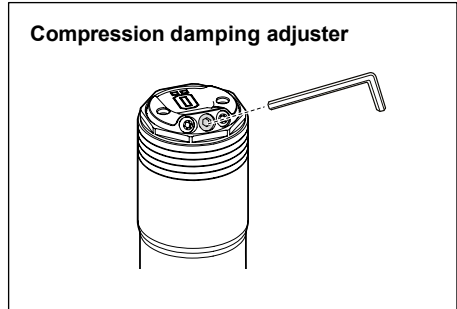

Diagram: Oil Volume - Force



Spring Guide

Spring Guide	Rider's weight*	Spring rate
	kg/pounds	N/mm
Motocross/Enduro 250	70/154	4,1-4,4
	75/165	4,3-4,5
	80/176	4,5-4,8
	85/187	4,6-4,9
	90/198	4,7-5,0
	95/209	4,8-5,1
Motocross/Enduro 450	70/154	4,3-4,6
	75/165	4,4-4,7
	80/176	4,5-4,8
	85/187	4,6-4,9
	90/198	4,7-5,0
	95/209	4,8-5,1

* Rider's weight: Rider wearing all riding equipment

Inspection and Maintenance

Preventive maintenance and regular inspection reduces the risk of functional disturbance.

Breather plug

Aerate the front fork at regular intervals:

1. Put the motorcycle on a workstand so that the front wheel is off the ground.
2. Loosen the breather plug to release excessive pressure in the front fork.

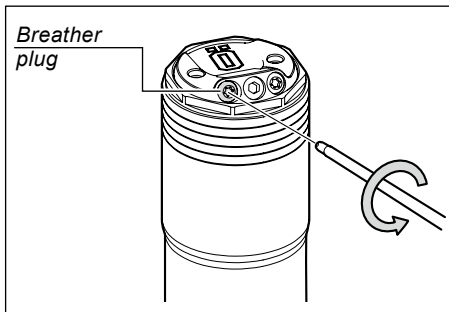

Cleaning the scrapers

The scrapers protect the fork tube from dust and dirt. After some use dirt may end up behind the scrapers. If this dirt is not removed the oil sealing rings may start leaking.

How to clean:

1. Lift scrapers out of the outer tubes with a screwdriver and slide them down.
2. Clean the scrapers, the outer tubes and the inner tubes thoroughly.
3. Lubricate inner surface with a thin layer of Öhlins grease 00159-01 and Öhlins Front Fork Fluid 01312-01, (leave outside dry). Reinstall the scrapers by pushing them into the outer tubes.

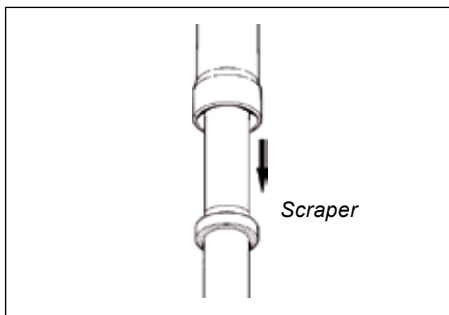

Inspect and/or Replace Seals and Bushings Disassemble

1

Follow steps 1-4 in "Replace spring" to disassemble the fork legs.

2

Remove cartridge, spring and plastic preload washers, drain the front fork fluid.

3

Remove scraper with a screwdriver and remove the seal circlip.

Note!

The fork legs have one fixed bushing and one sliding bushing. Be careful when disassembling the fork legs, use Öhlins tool 01702-04.

Inspection and Maintenance

4

Fasten the fork legs horizontally in a vice with soft jaws. Use a hot air gun to warm up the outer tube where the bushings are located.

5

To remove the bushings; Use Öhlins tool 01702-04 to separate inner tube from outer tube. Install the tool at the top of the outer tube. Rotate the tool to press out the inner tube with seals and bushings.

6

Remove the seals and bushings and check them for wear and damage. Replace if necessary.

Caution!

When removing and installing scraper and oil seal use thin plastic tape on the edges of the inner tube to avoid damage to the seals.

Assemble

7

Apply a thin layer of Öhlins grease 00159-01 and Öhlins Front Fork Fluid 01312-01 on the sealing surface of the scraper ring and the fork seal. Leave outer surface of the scraper ring dry. Install the scraper ring, circlip, oil seal, support ring and the bushing on the inner tube.

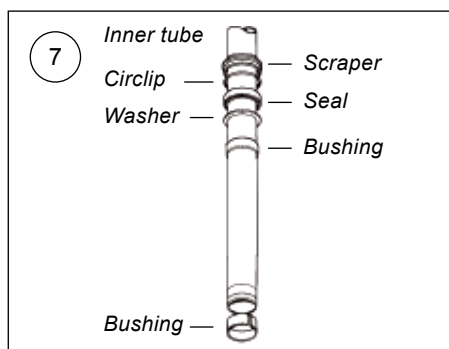
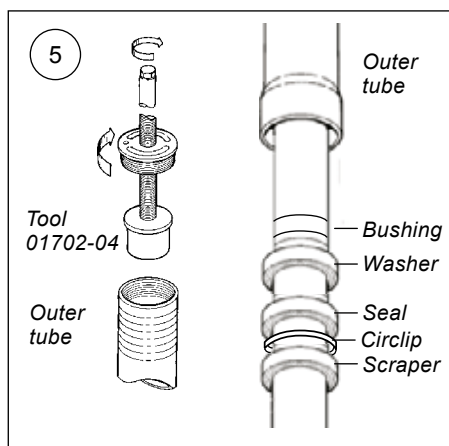
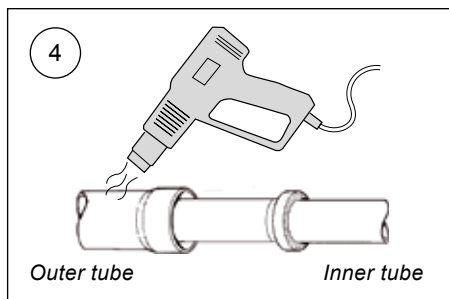

Inspection and Maintenance

8

Fasten the outer tube in a vice with soft jaws. Install the inner tube. Use tool 01799-04 to install the lower bushing.

Note!

Use a hot air gun to warm up the outer tube before installing the bushings.

9

Use tool 01799-04, flip it around to install the seal in the outer tube. Install the circlip and the scraper.

Caution!

Make sure the circlip is correctly fitted into the groove of the outer tube.

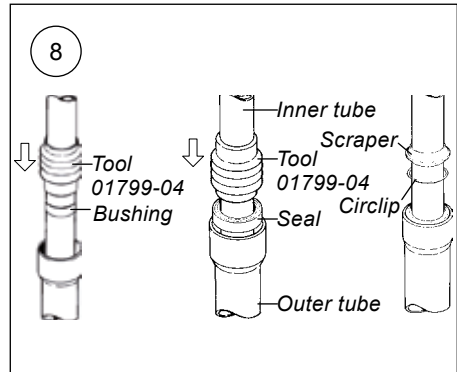

Remove and Inspect Cartridge, and Check Pressure

1

Follow steps 1-4 in "Replace spring" to disassemble the fork tubes.

2

Remove cartridge and inspect for wear or damage, replace parts if necessary.

Caution!

When compressing the damper cartridge fully, fluid might escape from top cap side hole.

3

Check pressure:

Compress the cartridge fully,

When releasing, the internal pressure should push back the cartridge to full length distinct stop.

Warning!

It is advisable to have an Öhlins dealer perform service on the damper cartridge.

4

Follow instructions from previous chapters to install front fork to the vehicle.

Inspection and Maintenance

Maintenance Intervals

Do not use strong solvents, such as brake cleaner to clean the front fork. This will dry out the seals and the tubes and cause friction or leakage.

After every race

Clean externally and spray with an all-purpose oil after washing with detergent.

Check externally for damage.

Every 20 hours

Dismantle the fork and check all parts for wear and damage, replace if necessary.

	After brake-in	Every race	Every 20 hrs	As required
Inspect and adjust	x	x	-	x
Clean and lubricate scrapers	x	x	-	-
Replace seal and scraper	-	-	-	x
Replace oil	x	-	x	-
Replace bushings	-	-	x	x
Service damper cartridge	-	-	x	x

Disposal

Discarded Öhlins products should be handed over to an authorized Öhlins workshop or distributor for proper disposal.



Your Öhlins retailer:



Öhlins Racing AB
Box 722
SE-194 27, Upplands Väsby
Sweden

Phone: +46 (0)8 590 025 00
Fax: +46 (0)8 590 025 80
www.ohlins.com



www.ohlins.com